

FEATURES

- ▶ Low-cost, high-performance replacement for many OEM DPMs
- ▶ Snap-in bezel mount eliminates mounting hardware
- ▶ Resistant to RF and EMI
- ▶ 3½ digits with high-contrast LCD
- ▶ 4- 20 mA loop powered input



SPECIFICATIONS

DISPLAY

Digits: 3 ½ digits (± 1999 counts)
 Type: 0.5" (12 mm) 7 segment LCD
 Polarity: automatic, "-" displayed
 Decimal Points: 3 position, user-selectable
 Overrange: three lower order digits blank for inputs >1999 & < -1999

INPUTS

Ranges: 4-20 mA DC
 Configuration: bipolar differential
 Protection: 30 mA max.
 Loop Burden: 300 Ω nominal

PERFORMANCE

Accuracy: $\pm(0.1\% \text{ fs} + 2 \text{ count})$
 Conversion Rate: 3 per second
 Normal Mode Rejection: $>30 \text{ dB @ } 60 \text{ Hz}$
 Adjustments: span (gain) and zero (offset)
 Warmup: 10 minutes typical
 Temperature Coeff.: $\pm 100 \text{ ppm per } ^\circ\text{C}$ typical

ENVIRONMENT

Operating Range: 0 to 50 $^\circ\text{C}$
 Storage Range: -10 to 70 $^\circ\text{C}$

POWER SUPPLY

powered by the milliamp control loop

MOUNTING

snap-in bezel mount

CONNECTION

2 screw terminal

ORDERING INFO

PART NUMBER

LPI-J1

ACCESSORIES

PW2-24 Regulated 120V AC to 24V DC Power Supply

CVC Calibrator



LCD Digital Panel Meters

3½ Digit LCD with Loop Powered Adder Board



DIMENSIONS

BEZEL MOUNT DIMENSIONS

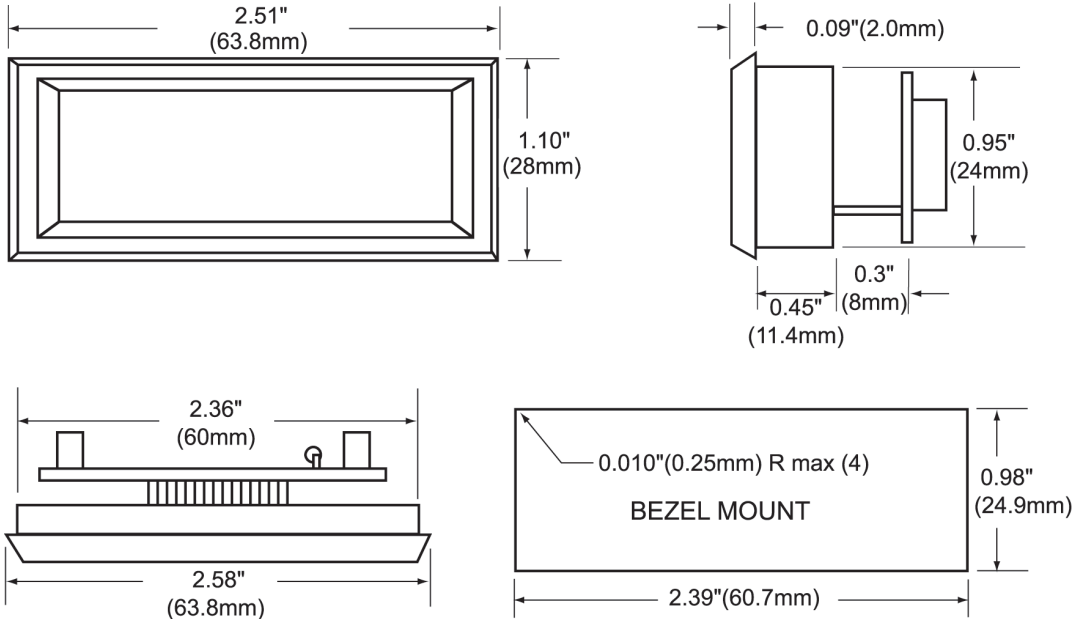

WIRING

1. DECIMAL SELECTION:

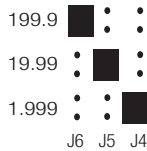

2. J1, J2, J3 SELECTION:

IF: OFFSET (ZERO) IS 0 or
 OFFSET (ZERO) > 0 and GAIN (SPAN) ÷ OFFSET (ZERO) ≥ 5



IF: OFFSET (ZERO) > 0 and GAIN (SPAN) ÷ OFFSET (ZERO) < 5

